

## Tensiometers for Soil Moisture Measurement and Irrigation Scheduling<sup>1</sup>

Allen G. Smajstrla and Dalton S. Harrison<sup>2</sup>

Tensiometers are instruments that are used to measure the energy status (or potential) of soil water. That measurement is a very useful one because it is directly related to the ability of plants to extract water from soil. Irrigators often use tensiometers for irrigation scheduling because they provide direct measurements of soil moisture status and they are easily managed. In addition, tensiometers can be automated to control irrigation water applications when the soil water potential decreases to a predetermined critical value.

permeability to water flow. The body tube is normally transparent so that water within the tensiometer can easily be seen. A Bourdon tube vacuum gauge is commonly used for water potential measurements. The vacuum gauge can be equipped with a magnetic switch for automatic irrigation control. A mercury manometer can also be used for greater accuracy, or a pressure transducer can be used to automatically and continuously record tensiometer readings. Figure 1 illustrates the components of one model of a commercially available tensiometer using a vacuum gauge.

### Tensiometer Components

A tensiometer consists of a porous cup, connected through a rigid body tube to a vacuum gauge, with all components filled with water. The porous cup is normally constructed of ceramic because of its structural strength as well as

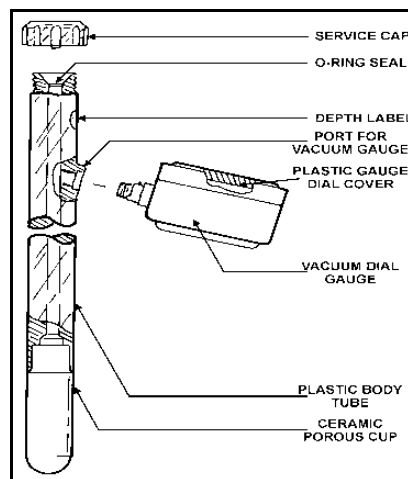

Figure 1. Tensiometer components.

Tensiometer cost depends on its length, or the depth at which it will be installed. In general, prices of standard, manually-read instruments range from about \$60 each for the 6-inch size to about \$75 for the 4-ft size. Automatic switching tensiometers cost about \$30 more. Vacuum gauge tensiometers are manufactured by several companies and are available at most irrigation supply businesses.

### Principle of Operation

Tensiometers are placed in the field with the ceramic cup firmly in contact with the soil in the plant root zone. The ceramic cup is porous so that water can move through it to equilibrate with the soil water. A partial vacuum is created as water moves from the sealed tensiometer tube. The vacuum causes a reading

1. This document is CIRCULAR 487, one of a series of the Agricultural & Biological Engineering Dept., Florida Cooperative Extension Service, Institute of Food and Agricultural Sciences, University of Florida. Date revised: April 1998. Please visit the FAIRS Web site at <http://hammock.ifas.ufl.edu>.
2. Allen G. Smajstrla and Dalton S. Harrison, Professor and Professor emeritus, respectively, Cooperative Extension Service, Institute of Food and Agricultural Sciences, University of Florida, Gainesville, 32611.

The Institute of Food and Agricultural Sciences is an equal opportunity/affirmative action employer authorized to provide research, educational information and other services only to individuals and institutions that function without regard to race, color, sex, age, handicap, or national origin. For information on obtaining other extension publications, contact your county Cooperative Extension Service office. Florida Cooperative Extension Service / Institute of Food and Agricultural Sciences / University of Florida / Christine Taylor Waddill, Dean

on the vacuum gauge which is a direct indication of the attractive forces between the water and soil particles. This reading is a measure of the energy that would need to be exerted by the plant to extract water from the soil.

Because the porous ceramic cup is permeable to both water and dissolved salts, tensiometers do not record the water potential due to dissolved salts (osmotic potential). The actual total potential that plants would need to overcome to extract water from soils includes the osmotic potential. If soils are saline, or if poor quality irrigation water is being used, the osmotic potential will be a large portion of the total potential. In those cases, osmotic potential should also be measured using soil salinity sensors.

As the soil dries, water potential decreases (tension increases) and the tensiometer vacuum gauge reading increases. Conversely, an increase in soil water content (from irrigation or rainfall) decreases tension and lowers the vacuum gauge reading. In this way, a tensiometer continuously records fluctuations in soil water potential under field conditions.

Rapid and accurate tensiometer response will occur only if air does not enter the water column. Air expands and contracts with changes in pressure and temperature, thus causing inaccurate tensiometer readings. Even if instruments do not have leaks, dissolved air enters with water flow through the ceramic cup during normal operation of the instrument. When a significant amount of air enters the instrument, it must be expelled and the tensiometer refilled with water before it will operate reliably again.

## Units of Measurement

The tensiometer measures water potential or tension. Water potential is commonly measured in units of bars (and centibars in the English system of measurement) or kilopascals (in metric units). One bar is approximately equal to one atmosphere ( $14.7 \text{ lb/in}^2$ ) of pressure. One centibar is equal to one kilopascal.

Because water is held by capillary forces within unsaturated soil pore spaces, its water potential is negative, indicating that the water is under tension and that work must be done to extract water from the soil. A water potential reading of 0 indicates that the soil is saturated, and plant roots may suffer from lack of oxygen. As the soil dries, water becomes less available and the water potential becomes more negative. The

negative sign is usually omitted for convenience when soil water potentials are measured with tensiometers. The negative sign will be omitted in this publication, and readings will be reported as soil water tensions.



Figure 2 illustrates the dial face of a typical tensiometer vacuum gauge. Divisions are in units of centibars (cb), with a range of 0-100 cb. Recently, one company began to manufacture a "Florida" tensiometer with a range of 0-40 cb. The expanded scale in this range is ideal for irrigation scheduling in typical Florida sandy soils.

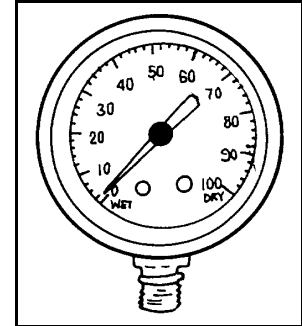

**Figure 2.** Typical vacuum gauge dial face with graduations in centibars.

## Range of Operation

Because of the vaporization of water at low pressure, the range of operation of a tensiometer is limited to 0 to about 85 cb. Above 85 cb the column of water in the plexiglass tube will form water vapor bubbles (cavitate), and the instrument will cease to function. This range represents only a fraction of the water tension range that is normally considered to be available for plant growth. Many plants can survive to a water tension of 15 bars. However, plant growth and productivity cease well before this point. In sandy soils, tensiometers measure the entire range of soil water tension of interest for irrigation. Thus, the tensiometer is an excellent instrument for irrigation management in Florida.

Research has shown that to optimize production, irrigation should be scheduled when soil water tension reaches 10-20 cb in sandy soils. The exact values to be used depend on soil hydraulic properties, crop susceptibility, and production objectives. These water tensions are well within the tensiometer range of application.

## Site Selection

Tensiometers measure soil water tension in only a small volume of soil immediately surrounding the ceramic cup. Therefore, the ceramic cup must be placed in the active root zone of the crop for which

irrigations are being scheduled. Depending upon crop type, two or more tensiometers may be required at a measurement site. Figs. 3 and 4 illustrate proper depths of installation for row crops and tree crops, respectively.

Because of differences in soil and plant characteristics, several measurement sites may be required to adequately assess the water status of large areas. For more valuable or more sensitive crops, more tensiometers should be used. For uniform soil types fewer tensiometers may be adequate.

The sites selected for installation should be representative of the surrounding field conditions. Isolated low, wet areas or high, dry areas should be avoided. Tensiometers should be placed within the plant canopy in positions where they will receive typical amounts of rainfall and irrigation.

Placement of tensiometers with depth is critical. For shallow-rooted (less than 1 ft) crops such as some vegetables, only one tensiometer may be required with depth. It should be centered in the crop root zone, but at least 4-6 inches below the surface. The ceramic cup should not be exposed to the atmosphere.

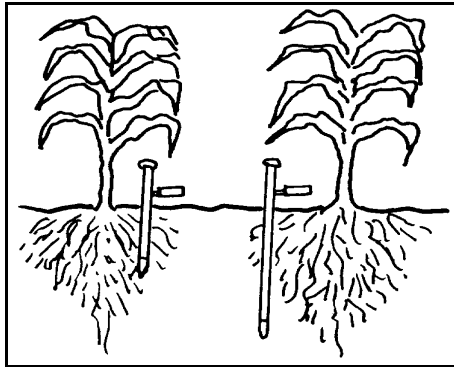

**Figure 3.** Tensiometer placement for row crop production systems.

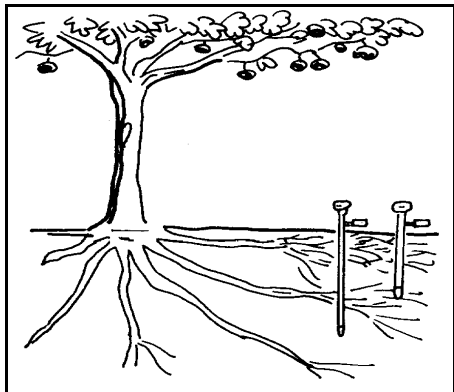

**Figure 4.** Tensiometer placement for tree crop production systems.

For crops with deeper root zones such as most field crops, two tensiometers should be used at each measurement site. The shallower one should be placed in the zone of maximum root concentration. This is normally at 6 inches or about one-third of the active rooting depth. In tree crops, depths of 6 to 24 inches are often used. Other depth combinations may be used where appropriate.

When multiple instruments are used, most irrigations will be scheduled to replenish the upper part of the root zone monitored with the shallow instrument. The deeper instrument will indicate when less frequent larger irrigations are needed to replenish the entire root zone.

## Installation

The tensiometer can be a useful instrument for irrigation scheduling only if it is properly installed. In general, proper installation requires that the instruments be in good hydraulic contact with the surrounding soil so that water can move into and away from them as efficiently as possible. In addition, tensiometers must be properly located in the crop root zone as discussed in the previous section on site selection.

Before field installation, each tensiometer should be tested to verify that it is operating properly. Fill each tensiometer with clean water (deionized water is preferred to help prevent organic growths) and allow it to stand in a vertical position for at least 30 minutes so that the ceramic tip will saturate. A plastic squeeze bottle and small diameter plastic tube can be used to fill the tube from the bottom to help eliminate air bubbles (Figure 5). When its tip is thoroughly wetted, it can be refilled and capped. The

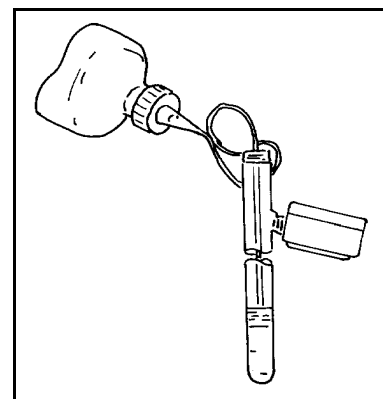

**Figure 5.** Filling a tensiometer using a plastic squeeze bottle and a small diameter flexible tube.

tensiometer will not be serviceable immediately because of air bubbles in the vacuum gauge.

A small hand vacuum pump (Figure 6), obtainable from tensiometer manufacturers, can be used to remove air bubbles and test for air leaks. This service will be necessary before installation as well as periodically in the field.

Tensiometers are installed in previously cored holes in the field. Manufacturers sell coring tools of the proper dimensions for tensiometer installation. In sandy soils, the access holes can be cored by hand, while on heavier soils it may be necessary to use a hammer to aid the installation (Figure 7).

The tensiometer is pushed into the access hole to the proper depth. In this position, the vacuum gauge will be located 2-3 inches above the soil surface. The soil around the tensio-meter should be tamped at the surface to seal the instrument from air contact with the ceramic cup and to prevent surface water from running down around the tube (Figure 8).

If commercially available coring tools are not available, a length of standard water pipe or other tubing of the proper diameter can be used with

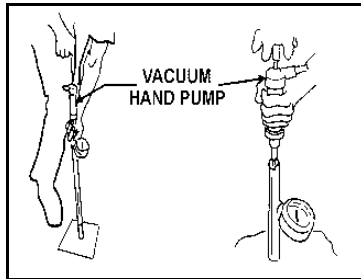

**Figure 6.** Using a vacuum hand pump to extract air from a tensiometer to test for leaks before installing and periodically in the field.

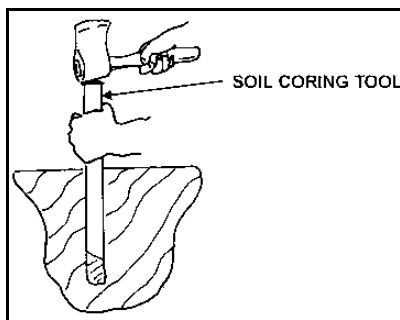

**Figure 7.** Installation procedure for heavy soils, using a commercially available soil coring tool.

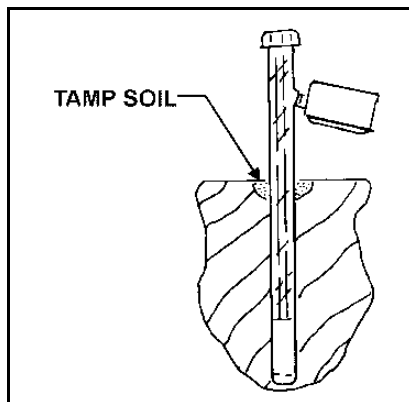

**Figure 8.** A properly placed tensiometer in the field.

acceptable results. It is critical, regardless of the installation method used that the ceramic cup be in intimate contact with soil in order for the tensiometer to function properly.

If a rock or other obstacle is encountered, the tensiometer should be moved to another location to avoid possible damage when it is placed in the cored hole. The tensiometer should not be driven into place with a hammer or other object. Although adequate for normal use, the mechanical strength of the ceramic cup is not adequate to allow it to be hammered into place.

In very loose cultivated soils, such as frequently encountered in commercial row crop production, it is possible to push shallow tensiometers into place without coring a hole. This method of installation is acceptable when applicable. Again, the surface soil must be firmly packed around the instrument after installation.

After installation, several hours may be required before the tensiometer reads the correct soil water potential value. This is because of the disturbance to the soil caused by the installation procedure, and because of the need for water to move through the ceramic cup before equilibrium is reached. The correct reading will be reached more quickly in moist soils than in dry soils. After this initial equilibrium period, the tensiometer will accurately indicate the soil water tension, and it will closely follow changes in tension as they occur in the soil.

Tensiometers are delicate instruments and should be protected from harm both before and after installation. They should be handled carefully and protected from impact by equipment or animals in the field. Also freezing conditions will damage tensiometers. They should not be left filled with water during freezing conditions.

## Field Service

To operate properly, tensiometers must be serviced in the field periodically. This is because with normal use, air is extracted from water under tension. The air becomes trapped within the tensiometer and reduces response time progressively until the instrument fails to operate.

If the soil in which the tensiometer has been installed is moist, soil tensions will be low and very

little air will accumulate. If, however, the tensiometer is installed in drier soils, with water potentials in the range of 40 to 60 cb, air will accumulate more quickly.

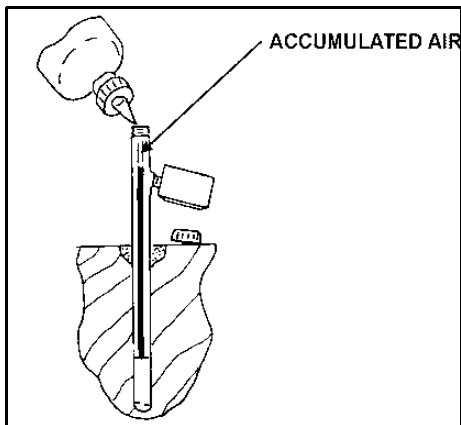

**Figure 9.** Refilling the tensiometer in the field to remove air bubbles.

The body tube should be inspected for accumulated air each time the tensiometer is read. If over 1/4 inch of air has accumulated beneath the service cap, the cap should be removed and the tube refilled with water as shown in Figure 9.

In wet soils, the tensiometer will probably need to be serviced approximately every 2 weeks. In dry soils, servicing may need to be more frequent, perhaps as often as every time the tensiometer data is collected.

### Irrigation Scheduling

Tensiometer measurements are useful in deciding when to irrigate because they give a continuous indication of soil water status, but they do not indicate how much water should be applied. The decision to irrigate is made when

the average tensiometer reading exceeds a given critical value. To optimize production the critical value is normally in the range of 10 to 20 cb for typical Florida sandy soils. The critical values are different for specific soil types, crops, and stage of crop growth. At critical stages of crop growth, lower values are used, resulting in irrigations being scheduled more frequently. The

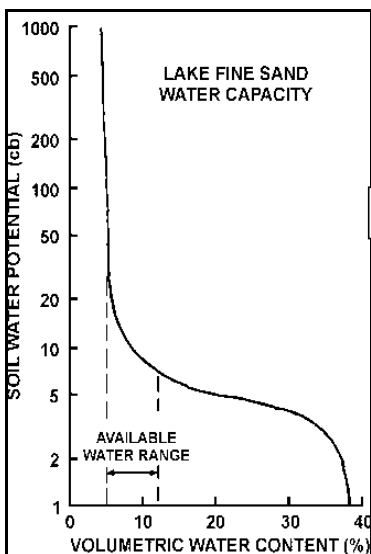

**Figure 10.** Soil water capacity function for lake fine sand.

critical values are also functions of economic considerations, with higher values set if the irrigated commodity price drops or if the cost of irrigation increases.

A tensiometer indicates only when irrigation should be scheduled, and not how much water should be applied. To determine the amount of water to be applied, a moisture characteristic curve specific for the

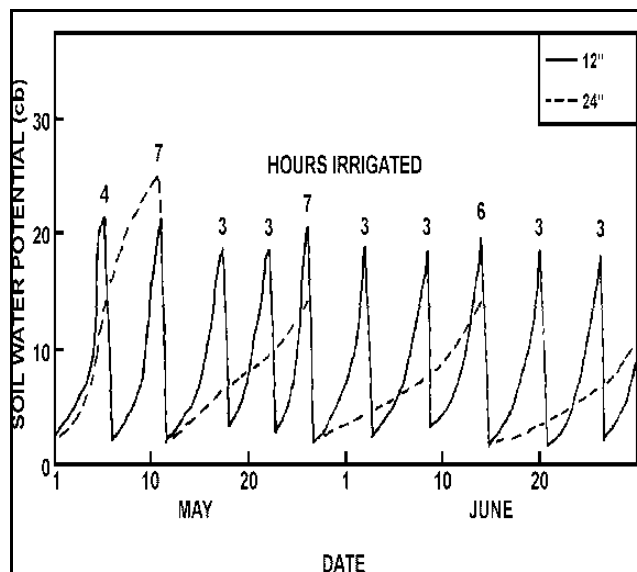
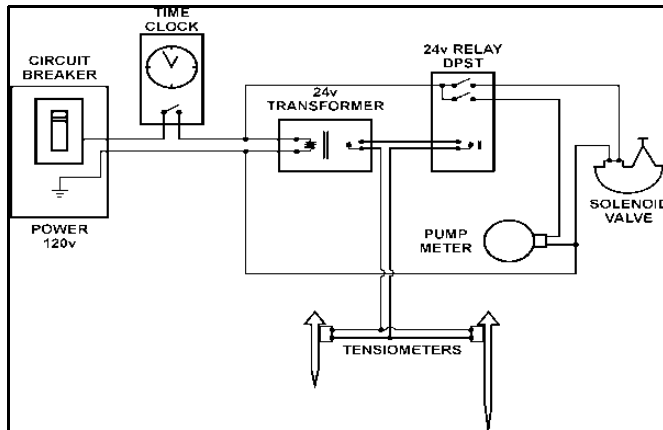

**Figure 11.** Irrigation scheduling and durations as controlled by tensiometers at two depths.

irrigated soil must be used. Figure 10 is a moisture characteristic curve for Lake Fine Sand, a typical deep sandy soil of central Florida. The depth of irrigation water to be applied should be adequate to restore only the root zone to field capacity. Excessive water will be lost to deep percolation below the crop root zone, carrying nutrients with it.

Figure 11 illustrates tensiometer field data and irrigations scheduled by the tensiometer method. In this illustration, timing and amount of irrigation were controlled with tensiometers at two depths. When the major root zone (12 inch) depth became as dry as desired, small irrigations were scheduled to rewet the 12-inch zone, but not the 24-inch depth which was still sufficiently wet. When, eventually, the 24-inch zone also reached the desired degree of dryness, a larger irrigation was scheduled to rewet the entire soil profile.

## Automated Tensiometers



**Figure 12.** Wiring diagram for automatic irrigation control.

A major advantage of tensiometers is that they can be instrumented to provide automatic control of irrigation systems. A modification is required to allow a tensio-meter to be used as an irrigation controller. The vacuum gauge is equipped with a magnet and a magnetic pick-up switch so that, when a desired (and preset) water tension occurs, the switch closes, starting the irrigation pump. The pump operates for a preset period of time, lowering the tensiometer reading, after which the tensiometer is again monitored until the critical water tension again occurs. A schematic of such an automatically controlled irrigation system is shown in Figure 12.

## Summary

Tensiometers are useful instruments for measurements of soil water status and irrigation scheduling. A tensiometer measures soil water tension, which is a measure of the energy required for plants to extract water from the soil. When used with a water characteristic curve, tensiometers can be used to indicate both the timing and amount of required irrigations.

Tensiometers are delicate instruments and must be properly handled and installed to assure that they will produce reliable results. When properly installed and maintained they will produce continuous records of soil water potential. In addition, tensiometers can be modified to automatically control irrigation systems.

## References

- Pair, C. H., ed. 1983. Irrigation. The Irrigation Association. Silver Spring, MD.
- Operating Instructions for the Model 2710 Soil Moisture Tensiometer. Soil Moisture Equipment Corp. Santa Barbara, CA.
- SCS. 1993. Soil-Plant-Water Relationships. In: SCS National Engineering Handbook. Section 15, Chapter 1. SCS. USDA. U.S. Government Printing Office. Washington, D.C.
- Smajstrla, A.G. and D.J. Pitts. 1997. Tensiometer service, testing and calibration. Ext. Bul. 319. Fla. Coop. Ext. Ser., Univ. of Fla., Gainesville, FL.